

Surface Mount

High Isolation Switch

50Ω SPDT, Absorptive DC to 4500 MHz

SWMA-2-50DR+

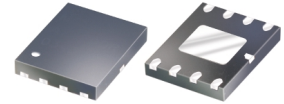

CASE STYLE: DL1020
PRICE: \$5.30 ea. QTY (10-49)

+ RoHS compliant in accordance with EU Directive (2002/95/EC)

The +Suffix has been added in order to identify RoHS Compliance. See our web site for RoHS Compliance methodologies and qualifications.

Maximum Ratings

Operating Temperature	-40°C to 85°C
Storage Temperature	-55°C to 100°C
Power and Voltage	see note 1

Pin Connections

RF IN	6
RF OUT 1	1
RF OUT 2	4
TTL IN	2
+5V	5
-5V	7
TTL GND	3
GND	8
GND	PADDLE

Outline Drawing

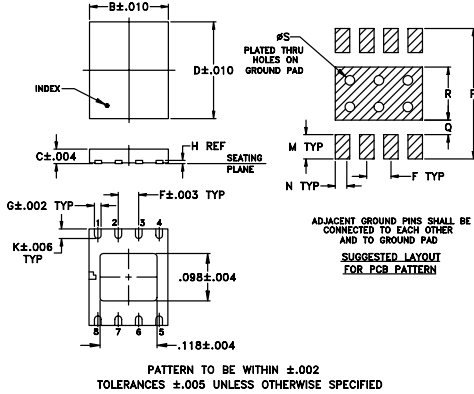

Outline Dimensions (inch/mm)

A	B	C	D	E	F	G	H	J	K
--	.193	.035	.236	--	.050	.017	.008	--	.024
--	4.90	0.90	6.00	--	1.27	0.43	0.20	--	0.60
L	M	N	P	Q	R	S	T	wt	
--	.050	.030	.270	.030	.110	.020	--	grams	
--	1.27	0.76	6.86	0.76	2.79	0.51	--	0.08	

Demo Board MCL P/N: TB-161

Suggested PCB Layout (PL-122)

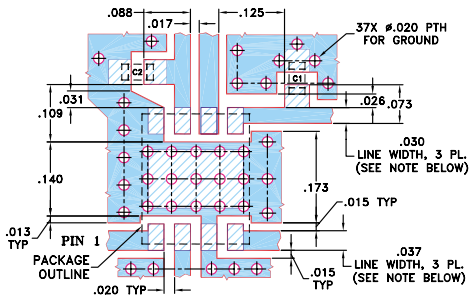

Features

- high isolation, 65 dB typ. at 1 GHz
- low insertion loss, 0.7 dB typ.
- integral TTL driver
- aqueous washable

Applications

- automated switching networks
- transmitters/receiver isolation

Electrical Specifications (T_{AMB}=25°C)

FREQ. (MHz)	INSERTION LOSS (dB)				1dB COMPR. (dBm)				IN-OUT ISOLATION (dB)			
	DC-100 MHz	100-1000 MHz	1000-2000 MHz	2000-4500 MHz	DC-100 MHz	100-1000 MHz	1000-2000 MHz	2000-4500 MHz	DC-100 MHz	100-1000 MHz	1000-2000 MHz	2000-4500 MHz
f _i	Typ.	Max.	Typ.	Max.	Typ.	Typ.	Typ.	Typ.	Typ.	Min.	Typ.	Min.
f _u	Max.	Typ.	Max.	Typ.	Max.	Max.	Max.	Max.	Max.	Max.	Max.	Max.
DC 4500	0.6	0.9	0.7	1.1	0.9	1.4	1.4	1.9	20*	25	25	24.7
									80	65	65	55
										55	45	38
												27

*drops to 17.0 dBm at 10 MHz

Switching Specifications

Power Supply Voltage	Current, mA	
+5V ±.20	9 max.	
-5V ±.20	9 max.	
TTL Control low threshold	Voltage, V	Current, mA
high threshold	0 min., 0.8 max.	0.2 max.
	2 min., 5 max.	5 max.
VSWR* (:1)	1.15 typ. to 2GHz, 1.3 typ. to 4.5 GHz	
Rise/Fall Time, ns	5 typ., 15 max.	
Switching Time, ns turn on/off	10 typ., 20 max.	
Video leakage**, mV p-p	30 typ.	

- * For all states of absorptive switch
** Video leakage or break through is defined as leakage of TTL switching signal to RF output ports.
1. Absolute maximum power and voltage rating:
RF input power, 250mW
Supply voltage: ±6V DC
 2. All RF inputs must be DC blocked or held at 0V DC

TTL	CONTROL LOGIC	
	RF1	RF2
LOW	ON	OFF
HIGH	OFF	ON

Electrical Schematic

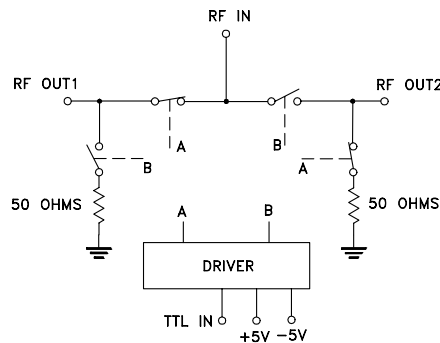

Mini-Circuits®
ISO 9001 ISO 14001 CERTIFIED

ALL NEW
minicircuits.com

P.O. Box 350166, Brooklyn, New York 11235-0003 (718) 934-4500 Fax (718) 332-4661 For detailed performance specs & shopping online see Mini-Circuits web site



The Design Engineers Search Engine Provides ACTUAL Data Instantly From MINI-CIRCUITS At: www.minicircuits.com

RF/IF MICROWAVE COMPONENTS

REV. E
M108294
SWMA-2-50DR+
ED-10679
RS/YB/CP
070228

Typical Performance Data

FREQ. (MHz)	INSERTION LOSS (dB) Control @ -5V IN-OUT		OFF ISOLATION (dB) Control @ 0V IN-OUT		VSWR			
	\bar{x}	σ	\bar{x}	σ	IN \bar{x}	ON	OUT	OFF
						\bar{x}	\bar{x}	\bar{x}
0.30	0.51	0.01	111.30	6.00	1.11	1.11	1.11	1.11
0.50	0.50	0.00	113.10	3.27	1.12	1.12	1.12	1.12
0.80	0.49	0.00	112.55	4.74	1.12	1.12	1.12	1.12
1.00	0.49	0.00	115.60	6.23	1.12	1.12	1.12	1.12
4.00	0.50	0.01	106.76	3.29	1.12	1.12	1.12	1.12
8.00	0.51	0.01	101.01	1.53	1.11	1.11	1.11	1.11
20.00	0.49	0.01	88.20	1.46	1.11	1.11	1.11	1.11
60.00	0.52	0.01	79.18	0.66	1.10	1.10	1.10	1.10
100.00	0.53	0.01	78.80	0.59	1.10	1.10	1.10	1.10
400.00	0.61	0.01	81.34	0.60	1.13	1.13	1.13	1.12
600.00	0.64	0.01	85.05	4.42	1.14	1.14	1.14	1.14
1000.00	0.70	0.01	68.29	1.98	1.15	1.17	1.17	1.19
1500.00	0.78	0.01	57.36	1.21	1.18	1.22	1.22	1.28
2000.00	0.88	0.01	50.71	0.80	1.28	1.32	1.32	1.39
2500.00	1.05	0.01	43.74	0.52	1.41	1.45	1.45	1.51
3000.00	1.25	0.01	40.47	0.42	1.54	1.53	1.53	1.55
3500.00	1.44	0.01	35.31	0.33	1.55	1.52	1.52	1.45
4000.00	1.74	0.01	31.80	0.15	1.41	1.33	1.33	1.22
4250.00	1.72	0.03	31.76	0.24	1.32	1.22	1.22	1.16
4500.00	1.60	0.02	30.69	0.16	1.19	1.21	1.21	1.12

